

La gamme la plus complète pour votre fin de ligne

Formeuses de caisses



BEM 100



BEM 200



BEM 200xs



BATEC



BEM XL

Solutions d'encaissage



ZENIT



SWING



Bizzy



Robot collaboratif



Solutions robotiques

Fermeuses automatiques de caisses



CS15



CS25



CS35



CS45

Palettiseurs



4AXIS



Cobot



Cellules de palettisation compactes



Robot palettiseur

Banderoleuses de palettes automatiques



LINE



SPIN



COVER

Banderoleuses de palettes Semi-automatiques



Single+ 2.0 FM



Single+ 2.0



Single+ 2.0 TP



SENIOR A 2.0



Fenix+



Ronda 900+



Rotex 700



Rotex 800

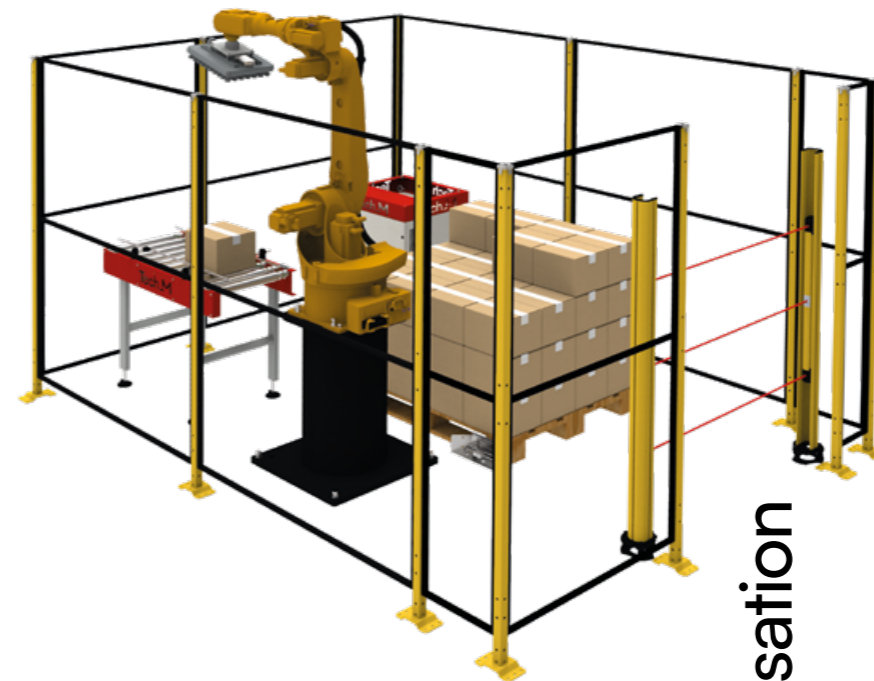

M_PAL
Cellule de palettisation
compacte

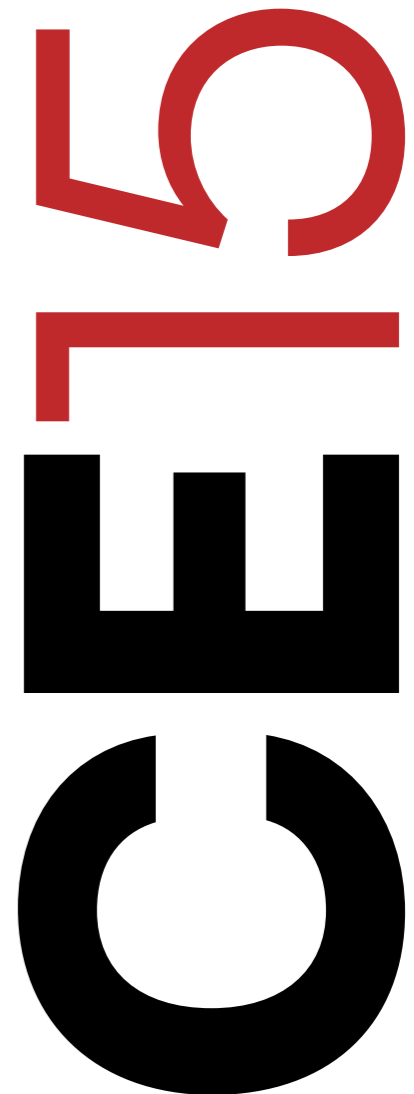

CE15

Tech_M

POSTE DE CHARGEMENT ET DE DÉCHARGEMENT MANUEL

M_PAL Cellule de palettisation compacte

Optimisez la palettisation de vos caisses avec cette cellule hautement efficace qui s'intègre facilement dans n'importe quel espace de votre ligne de production.

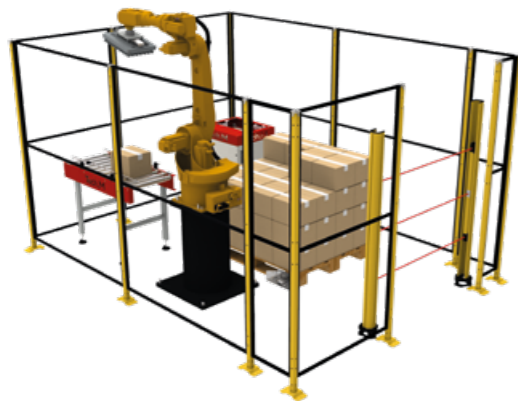

PRODUIT

Type	Caisses
Mesures	400x300x300 mm
Poids	17 kg

PRODUCTION

8 cycles/min

PALET

Mesures max.	1200x1000 mm
Hauteur	1700 mm (opt. 2400 mm)

COMPOSANTS

- 1 Convoyeur à rouleaux motorisés — entrée des caisses
- 2 Robot de palettisation ESTUN modèle ER20B-1760
- 3 Butée de positionnement palette
- 4 Barrière de sécurité
- 5 Ensemble de clôture de protection
- 6 Armoire de commande

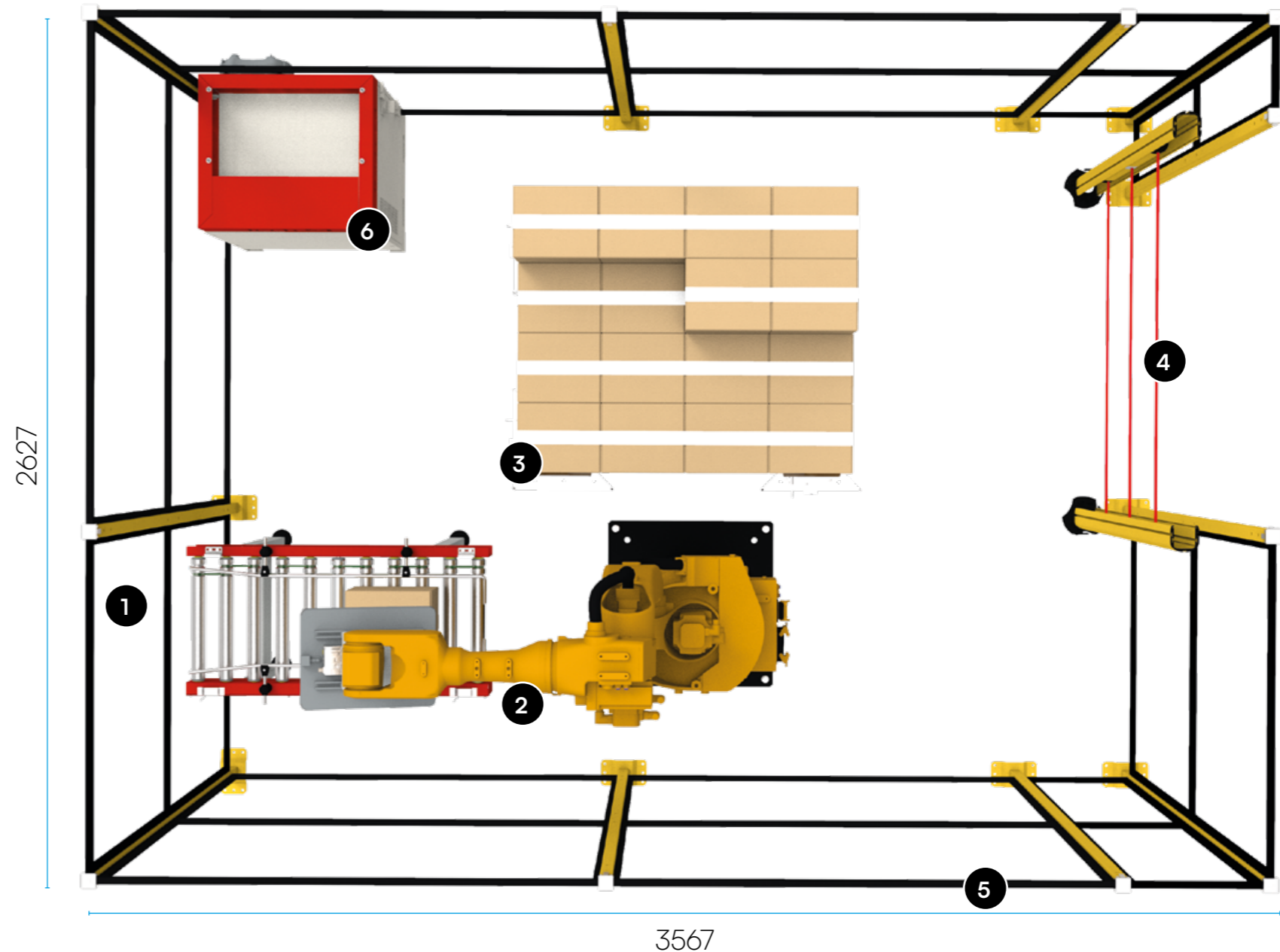

Autres configurations disponibles

2 STATIONS AVEC CHARGEMENT ET DÉCHARGEMENT MANUELS

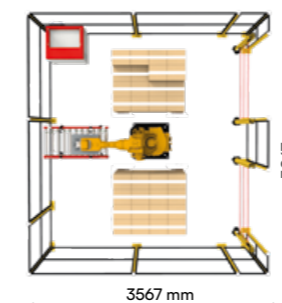

TRANSPORTEUR MOTORISÉ DE PALETTES

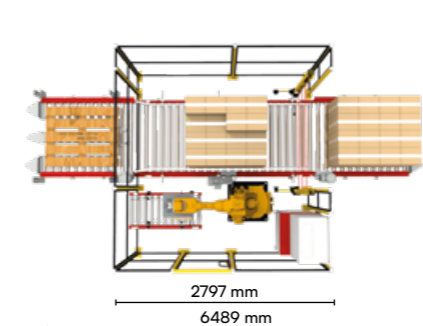

DISTRIBUTEUR DE PALETTES ET TRANSPORTEUR MOTORISÉ

