

## The most complete range for your end-of-line

### Case erectors



BEM 100



BEM 200



BEM 200xs



BATEC



BEM XL

### Packing solutions



ZENIT



SWING



Bizzy



Collaborative robot



Robotic solutions

### Case sealers



CS15



CS25



CS35



CS45

### Palletizers



4AXIS



Cobot



Compact palletizing cells



Palletizing robot

### Pallet wrappers



LINE



SPIN



COVER

### Semi-automatic pallet wrappers



Single+ 2.0 FM



Single+ 2.0



Single+ 2.0 TP



SENIOR A 2.0



Fenix+



Ronda 900+



Rotex 700



Rotex 800

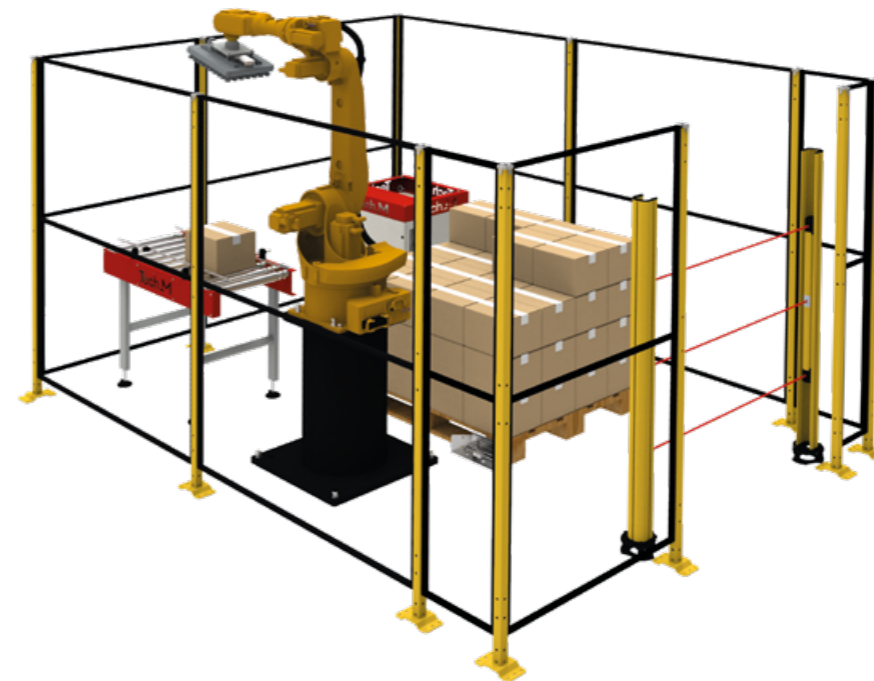

**M\_PAL**  
Compact  
palletizing cell



# CE15

## M\_PAL Compact palletizing cell

Optimize the palletizing of your boxes with this highly efficient cell that integrates easily into any space on your production line.

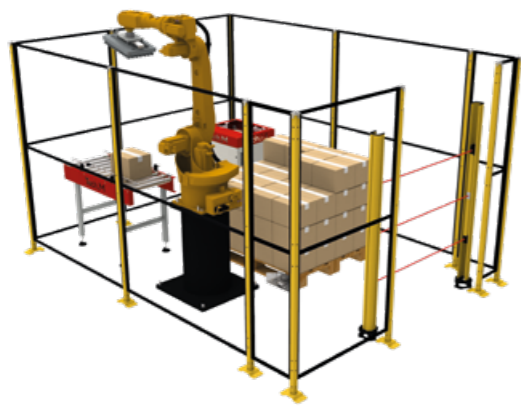

### PRODUCT

Type	Cajas
Dimensions	400x300x300 mm
Max. weight	17 kg

### PRODUCTION

8 cycles/min

### PALET

Max. dimensions	1200x1000 mm
Height	1700 mm (opc. 2400 mm)

### COMPONENTS

- 1 Motorized roller conveyor — box infeed
- 2 ESTUN palletizing robot, model ER20B-1760
- 3 Pallet positioning stop
- 4 Safety barrier
- 5 Protective fencing assembly
- 6 Control panel

### MANUAL LOADING AND UNLOADING STATION

Tech\_M

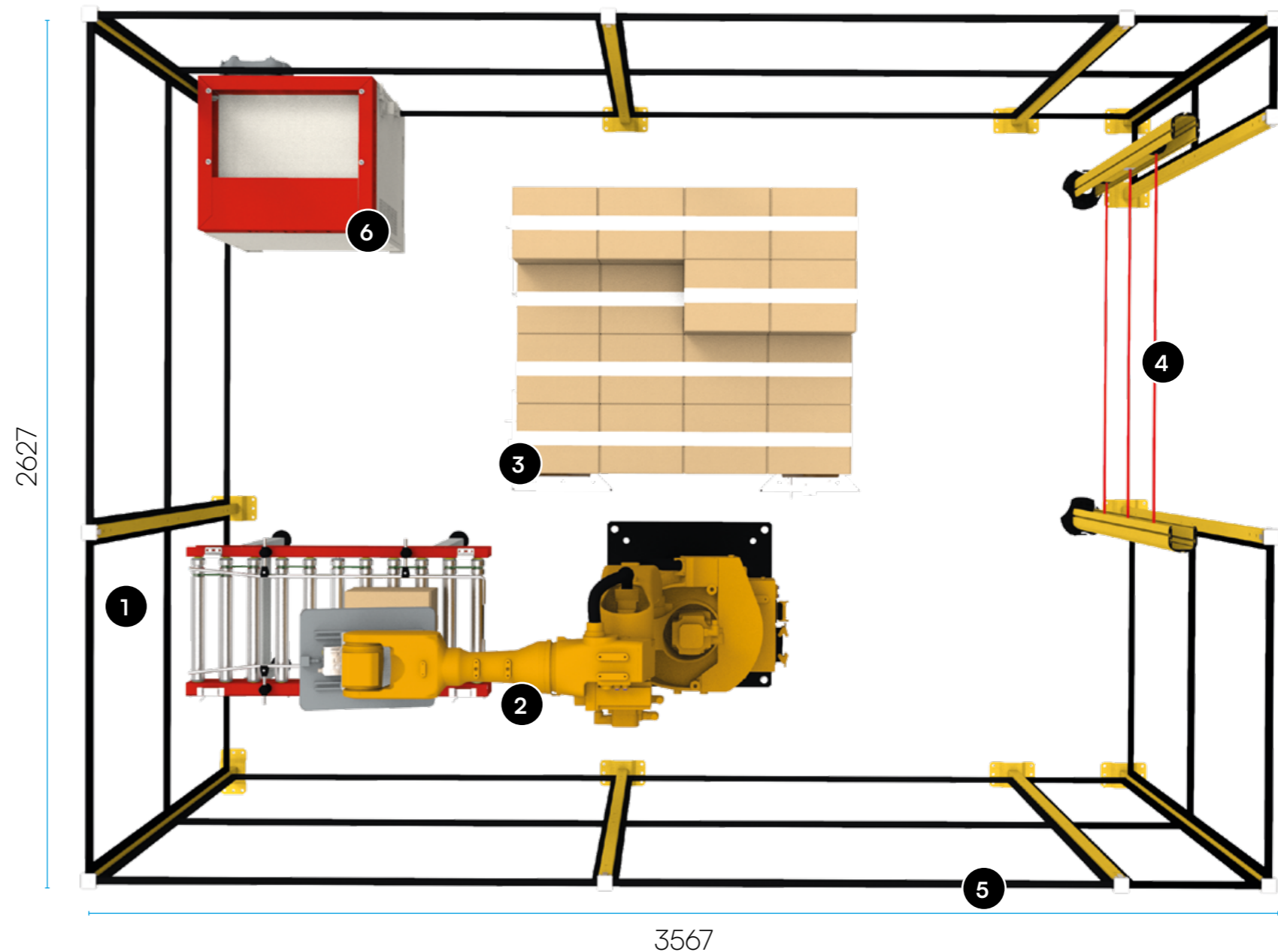

### Other configurations available

2 STATIONS WITH MANUAL  
LOADING AND UNLOADING

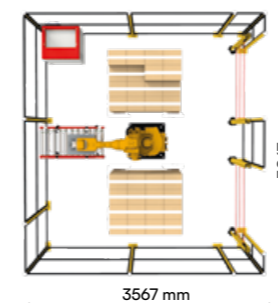

MOTORIZED PALLET  
CONVEYOR

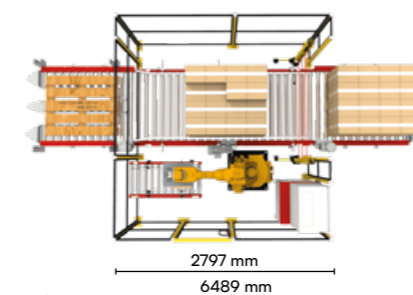

PALLET DISPENSER WITH  
MOTORIZED CONVEYOR

