

La gama más completa para tu final de línea

Formadoras de cajas



BEM 100



BEM 200



BEM 200xs



BATEC



BEM XL

Soluciones de encajado



ZENIT



SWING



Bizzy



Robot colaborativo



Soluciones robóticas

Precintadoras de cajas



CS15



CS25



CS35



CS45

Paletizadores



4AXIS



Cobot



Células compactas de paletizado



Robot paletizador

Enfardadoras de palets automáticas



LINE



SPIN



COVER

Enfardadoras de palets semiautomáticas



Single+ 2.0 FM



Single+ 2.0



Single+ 2.0 TP



SENIOR A 2.0



Fenix+



Ronda 900+



Rotex 700



Rotex 800

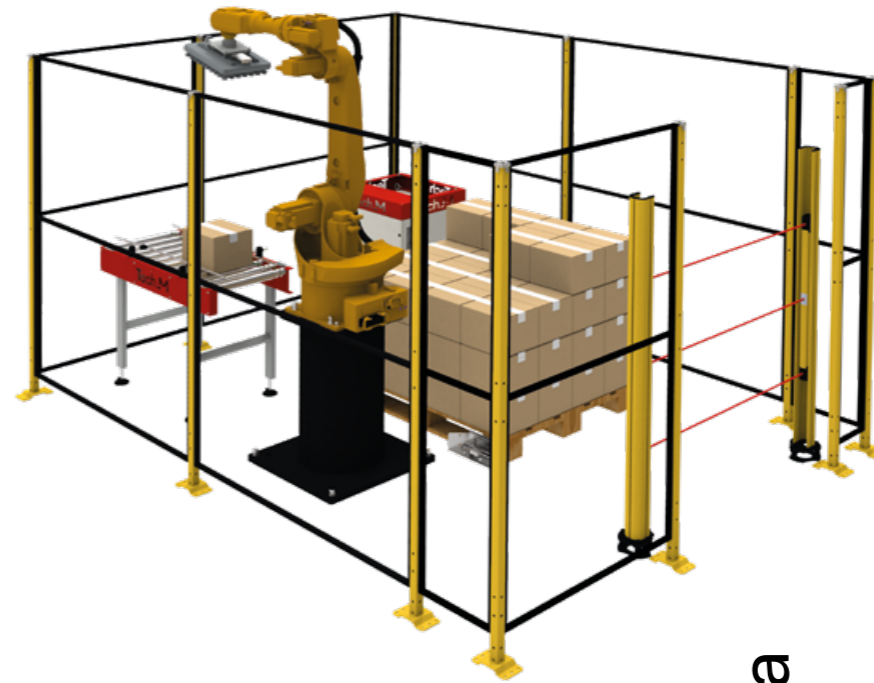

M_PAL
Célula compacta
de paletizado

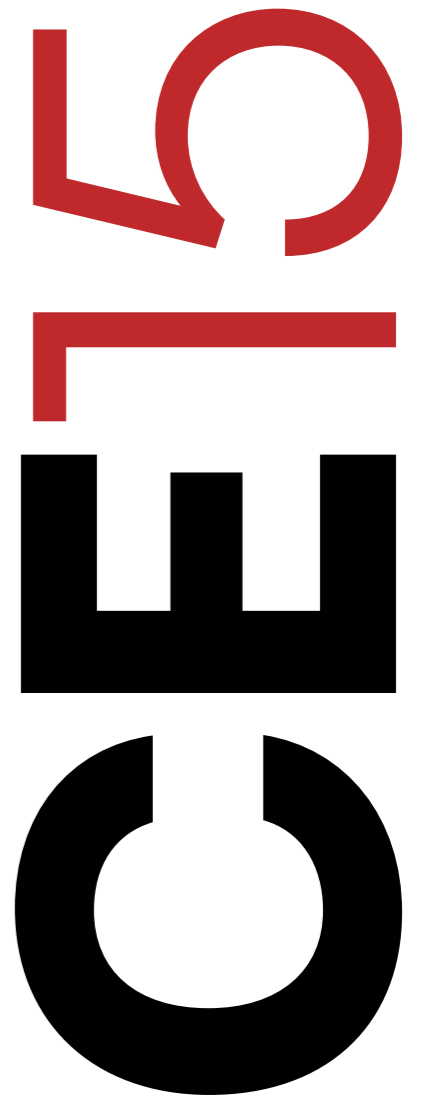

CE15

M_PAL Célula compacta de paletizado

Optimiza el paletizado de tus cajas con esta célula altamente eficiente que se integra fácilmente en cualquier espacio de tu línea de producción.

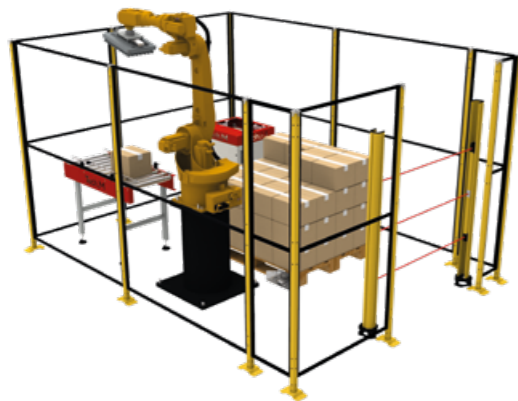

PRODUCTO

Tipo	Cajas
Medidas máx.	400x300x300 mm
Peso máx.	17 kg

PRODUCCIÓN

8 ciclos/minuto

PALET

Medidas máx.	1200x1000 mm
Altura	1700 mm (opc. 2400 mm)

COMPONENTES

1	-
2	-
3	-
4	-
5	-
6	-

Tech_M

1 ESTACIÓN: CARGA Y DESCARGA MANUAL

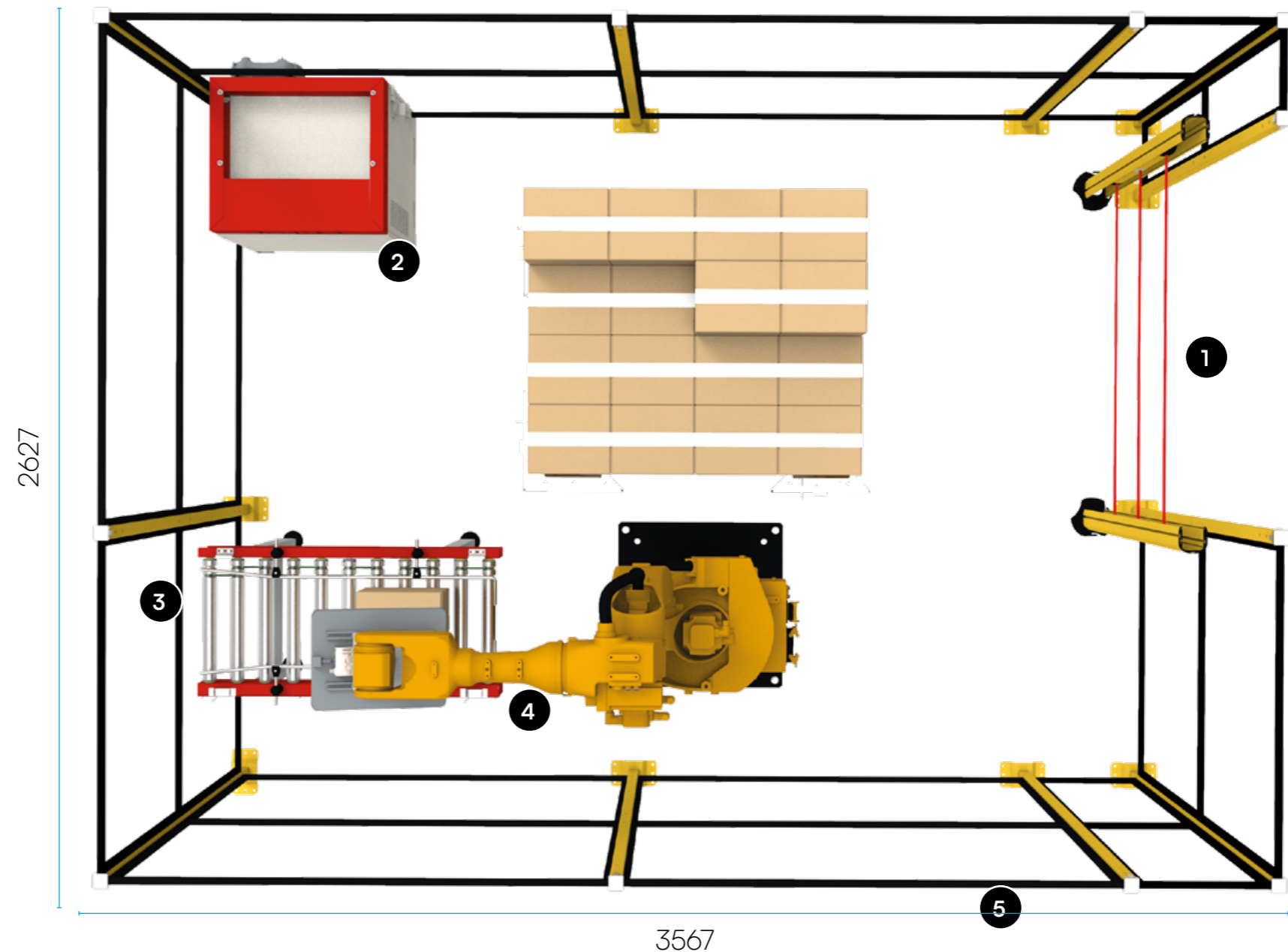

Otras versiones disponibles

2 ESTACIONES: CARGA Y DESCARGA MANUAL

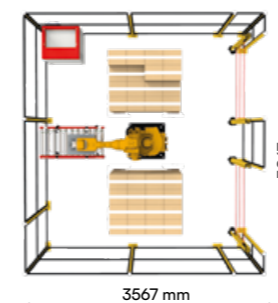

TRANSPORTE MOTORIZADO DE PALETS

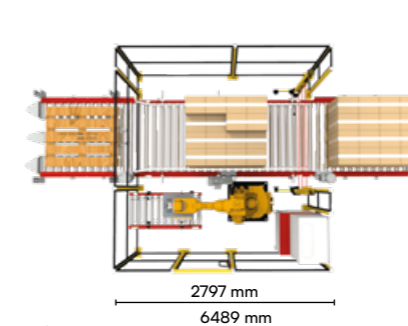

DISPENSADOR DE PALETS Y TRANSPORTE MOTORIZADO

